

# 2.5kWh Battery System

Power Battery 5.0/7.5/10.0/12.5/15.0



**GET A TASTE OF ENERGY  
INDEPENDENCE TODAY.**

The future of solar storage is here.  
Spiced with German technology.  
Refined with elegance.

---

**RCT**   
power

**Quick  
Installation Guide**

# I. Safety



- Only carry out electrical work when the power is off.
- Touching conductive parts can cause cardiac arrhythmia and shock.
- Do not operate defective cables or components with damaged housings.
- Carry out all electrical installations in accordance with local and national standards and directives.



- Use only suitable protective and measuring equipment.
- Do not subject components to pressure or impact. In particular, ensure that they do not fall over or drop during assembly.
- Do not place tools or metal parts on the components.
- Keep clearances to ensure cooling by convection.



- Ensure correct earthing when mounting the components.
- Ensure that no explosive gases, liquids or other substances are stored or used in their vicinity.
- Do not install the Battery System in rooms where there is a risk of explosion.
- Use a wall bracket to secure the Battery System against falling over.

# II. System Composition

## 2.1 Battery System

- The Battery System consists of one Battery Master, 2 to 6 Battery Stacks and one base. The energy storage system supports expansion. The capacity of a single Battery Stack is 2.5kWh, and each cluster of batteries can be expanded to a maximum of 6 Battery Stacks.
- The Battery System supports parallel expansion, allowing up to two clusters of batteries to be connected simultaneously, and the number of Battery Stacks in the two parallel clusters must be consistent.

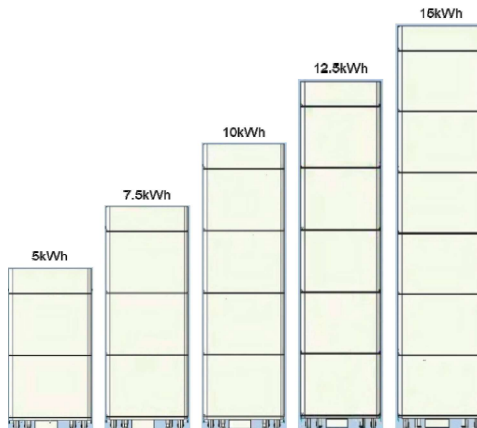

The energy of Battery System	Number of Battery Master	Number of Battery Stacks	Number of Battery Base	Dimensions ( W * D * H )	Weight
5.0 kWh	1	2	1	347X345X599mm	59kg
7.5 kWh	1	3	1	347X345X826mm	84kg
10.0 kWh	1	4	1	347X345X1053mm	109kg
12.5 kWh	1	5	1	347X345X1208mm	134kg
15.0 kWh	1	6	1	347X345X1507mm	159kg

## 2.2 Scope of Delivery

Before shipment, we will check whether the products are in good condition. Despite careful packaging, transportation damage may occur, and the transportation company is generally responsible for compensating for the losses. If you find any damage to the packaging or Battery System, please notify the shipping company or RCT Power immediately.



Pos.	Beschreibung
1	1x Battery Master
2	1x Wall Bracket used to fix the upper part of the Battery Stack onto the wall
3	2x Handle
4	1x Battery Base(adjustable)
5	1x Screw mounting kit
6	1x Quick Installation Guide (this document)
	1x Accessory packaging with:
	- 1x BAT+ Cable
	- 1x BAT- Cable
7	- 1x Patch cable RJ 45/Cat5e
	- 2x Ring terminal for grounding
	- 4x M5 Screws
	- 1x T25 Torx key
8	Battery Stacks

# III. Module Description

## 3.1 Battery Master

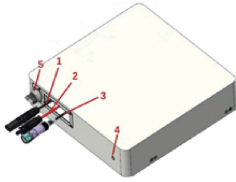

Fig.3-1 The top of the Battery Master

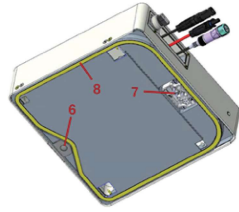

Fig.3-2 The bottom of the Battery Master

- |   |  |
|---|--|
| 1 | DC cable (-) to the Power Storage Inverter                 |
| 2 | DC cable (+) to the Power Storage Inverter                 |
| 3 | RJ45 connector for network cable to Power Storage Inverter |
| 4 | PE connection for protective conductor                     |
| 5 | DC switch  |
| 6 | LED status indicator                                       |
| 7 | Floating connector to stack                                |
| 8 | Sealing strip  |

Note: When the battery system leaves the factory, all the terminals shown in the picture will be installed before shipment.

## 3.2 Battery Stack

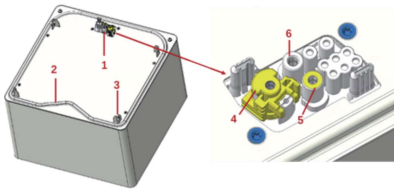

Fig.3-3 The top of the Battery Stack

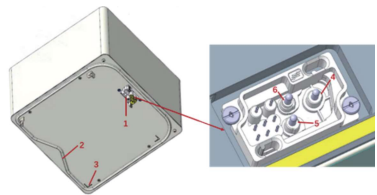

Fig.3-4 The bottom of the Battery Stack

- |    |  |
|----|--|
| 1. | Floating connector                     |
| 2. | Sealing strip                          |
| 3. | L-shaped positioning                   |
| 4. | To " + " for upper Battery Stack       |
| 5. | To " - " for upper Battery Stack       |
| 6. | To " PE Cable" for upper Battery Stack |

- |    |  |
|----|--|
| 1. | Floating connector                     |
| 2. | Sealing strip                          |
| 3. | L-shaped positioning                   |
| 4. | To " - " for lower Battery Stack       |
| 5. | To " + " for lower Battery Stack       |
| 6. | To " PE Cable" for lower Battery Stack |

### 3.3 Battery Base

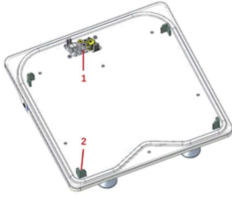

Fig.3-5 The top of the Battery Base

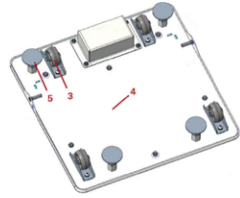
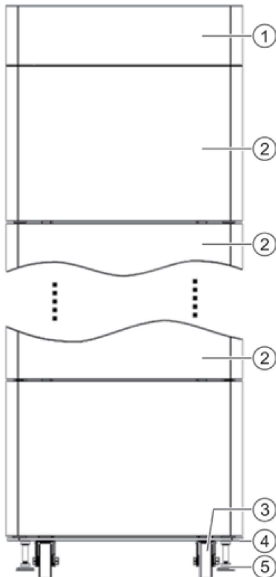

Fig.3-6 The bottom of the Battery Base

1	Floating connector
2	L-shaped positioning
3	Wheels of base plate
4	Base plate
5	Pedestal adjustable

## IV. Mechanical Assembly



- \_\_\_\_\_ 1. Battery Master
- \_\_\_\_\_ 2. Battery Stack
- \_\_\_\_\_ 3. Wheels of base plate
- \_\_\_\_\_ 4. Base plate
- \_\_\_\_\_ 5. Pedestal adjustable

The Battery System is subsequently

- plugged together on its base plate (④)
- wired
- screwed to the wall

## 4.1 Determine Installation Location and Level the Base Plate

- Position the base plate at the designated installation location, with the side equipped with the floating connector facing the wall. Maintain adequate clearance from the wall to allow sufficient space for subsequent cabling and installation.
- A clearance of approximately 30 mm from the wall is recommended. Using a spirit level, adjust the leveling feet on the base plate until the base plate is perfectly level and stable.



## 4.2 Secure the Base Plate Screws

- After leveling is completed, tighten the locking nuts on the base plate to secure the adjustable feet at the correct height.
- Once the locking nuts are tightened, place the base plate back into its installation position and recheck the level using a spirit level.

## 4.3 Determine Wall Mounting Height and Drill Holes

- Use a laser level to mark the installation position on the wall corresponding to the base plate. Based on the number of battery stacks and their corresponding height, mark the drilling positions on the wall accordingly.

**Note:** Before drilling, remove the base plate from the installation area and move it to a clean location to prevent dust and debris from accumulating on it.

- After drilling, reposition the base plate according to the laser level marks.
- When drilling, it is recommended to reserve approximately 10 mm of single-side adjustment margin on the expansion bolt height to accommodate minor irregularities in the floor surface. The distance between the two mounting holes is 165 mm.

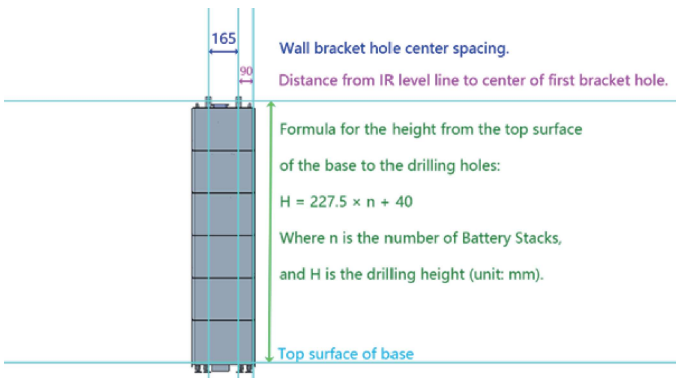

**Note:** Fine adjustments to the hole height may be made on site based on the actual requirements of the base plate leveling feet.

## 4.4 Stack the Battery Modules

- Using the supplied mounting handles (see item "3" in Section 2.2), place the battery stack onto the base plate with the connectors facing the wall. If the stack is positioned correctly, it will self-center automatically.

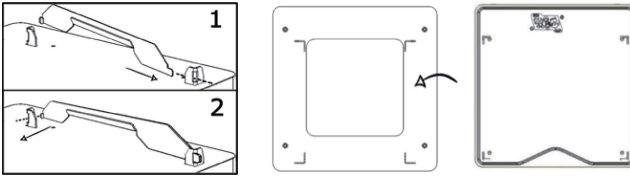

- During installation, ensure that no cables are pinched and that all components of the battery stack remain parallel to the ground.

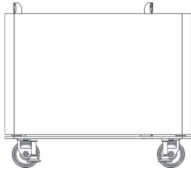

- Place another battery stack on top of the previous one, ensuring that both are parallel to each other. If the stack is positioned correctly, it will self-center automatically.
- Continue adding additional stacks until all battery stacks of the battery system have been fully installed.

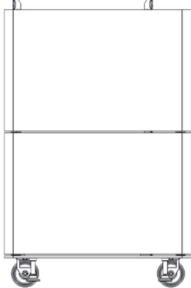

## 4.5 Install the Wall Bracket and Tighten the Screws

- Secure the wall bracket to the top battery stack using two M5 screws (①).
- Align the wall bracket with the drilling marks (③) on the wall at the vertical center of the slotted holes (②). To prevent the battery system from accidentally tipping over, fasten the bracket to the wall using expansion bolts.
- Place the Battery Master on top of the battery stack, ensuring that the red and black DC cables remain free and are not pinched.

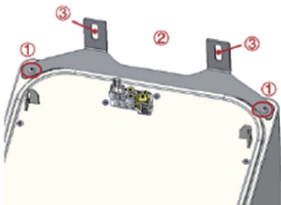

## 4.6 Install the Battery Master Module (BMS)

- Press down on the Battery Master to compress the sealing strip.
- Use 4 screws for installation. First, install two screws diagonally, then install the remaining two screws.

**Note:** The sealing strip must remain compressed during screw installation. If the sealing strip is not fully compressed, the screw will not properly enter the hole when tightened, which may cause deformation of the L-shaped positioning bracket.

# V. Electrical Installation

## 5.1 Electrical Installation

- There are three earthing positions, which need to be connected to the homeowner's distribution box

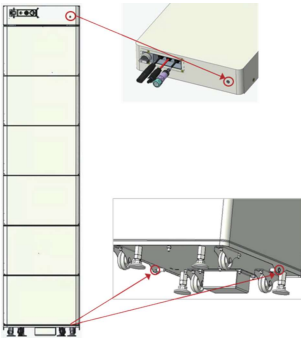

- Protective conductor connection in detail, tighten the nuts of the PE connections with 22in-lbs (2.5Nm):

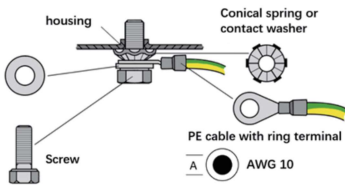

## 5.2 Establishing a Network Connection

- Plug the network cable to the "COM" side in the Battery Master, then plug the other side to the BMS port in the Inverter side.

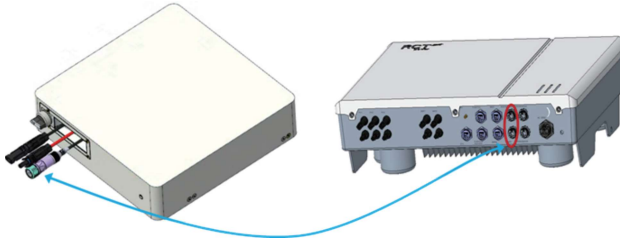

## 5.3 Establishing the DC Connection

- Connect the DC cable "+" of the Battery Master to the "BAT +" Port on the Inverter side.
- Connect the DC cable "-" of the Battery Master to the "BAT -" Port on the Inverter side.

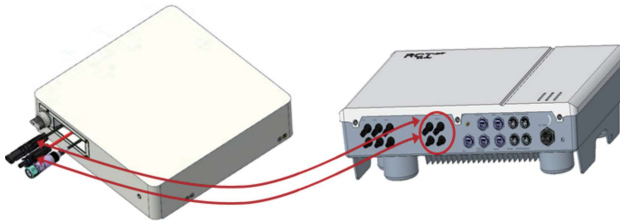

- Connect the DC cable "+" of the Battery Master to the "BAT +" Port on the Inverter side.
- Connect the DC cable "-" of the Battery Master to the "BAT -" Port on the Inverter side.

### Note:

- When the matched hybrid inverter models are RHS-3,68K-H,RHS-4K-H,RHS-5K-H,and RHS-6K-H, directly connect the BAT-INV terminal as described above.
- When the matched hybrid inverter is of another model, please follow these steps: For the cables of the battery system accessories (the BAT + cable and BAT- cable in Section 2.2), cut off the terminals at one end of them, then crimp them using the BAT + and BAT- terminals provided in the inverter accessories, and finally complete the connection of BAT- INV. As shown in the following figure:

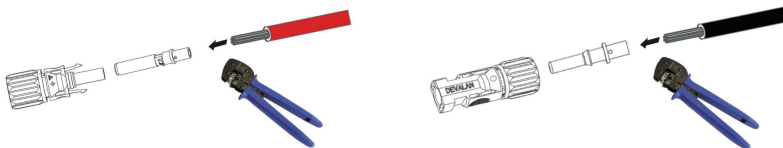

## 5.4 Parallel Connection of Battery System

- When the number of parallel battery systems is  $\geq 2$  and the BAT interface of the hybrid inverter is insufficient, the Y-type terminal should be adopted to realize the connection of power supply and communication.
- Take the parallel connection of four battery systems as an example:

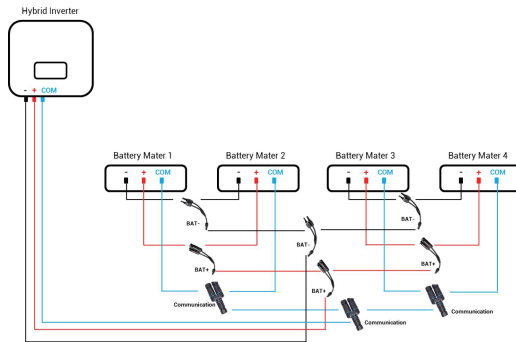

## VI. Commissioning

### 6.1 Inspection before Powering On

When powering on the Battery System, ensure that the following items are checked to prevent system damage.

- The inverter is firmly installed, the installation position is convenient for operation and maintenance, the installation space is convenient for ventilation and heat dissipation, and the installation environment is clean and tidy.
- Check if all cables are properly connected.
- Cables are bundled according to cable routing requirements, properly distributed, and without damage.
- The unused port is blocked.

## 6.2 Power on Battery System

- Circuit breakers between inverters and batteries must be installed according to local laws and regulations.
- Power on the inverters in the system. For details, see the inverter user manual of the corresponding model.
- Rotate the DC switch on the Battery Master to the "ON" position. Observe the LED indication.

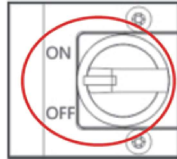

DC Switch

## 6.3 Setting Battery Parameters

After the successful communication connection between the Battery System and the inverter, set the correct parameters in the RCT RESS APP.

## 6.4 Power off Battery System

When turning off the Battery System, follow the sequence of steps below to prevent damage to the system:

- Rotate the DC switch on the Battery Master to the "OFF" position. Observe the LED indication.
- Check that the LED indicator of the Battery System is off.

## VII. Exclusion of Liability

Although the information contained in this manual has been carefully checked for accuracy and completeness, no liability can be assumed for errors or omissions.

RCT Power reserves the right to change the hardware and software features described in this manual at any time without prior notice.

Warranty or liability claims of any kind are excluded due to one or more of the following reasons:

- Incorrect use or installation of the product.
- Installation or operation of the product in an unsuitable environment.
- The relevant safety regulations during installation and commissioning at the operation site are ignored.
- The product relevant safety notices and instructions contained in the product documentation are ignored.
- By installing or operating the product under insufficient safety and security conditions.
- By modifying the product or by unauthorized software installation.
- A defect in the product caused by the operation of the product or adjacent equipment outside the permitted limits.
- Damage caused by force majeure.

This manual, in whole or in part, may not be reproduced, transmitted, copied or translated into other languages in any form or by any means, without the prior written permission of RCT Power.

RCT Power does not accept any liability for damage caused by incorrect or lost data, due to incorrect operation or malfunction of the hybrid inverter, the software, additional devices or personal computers.

# Technical Data

POWER BATTERY	2.5 <sup>1</sup>	5.0	7.5	10.0	12.5	15.0
<b>ELECTRICAL PARAMETERS</b>						
Nominal capacity [kWh]	2.5	5	7.5	10	12.5	15
Usable capacity (90% DoD) [kWh]	2.25	4.5	6.75	9	11.25	13.5
Cycle Life	≥ 8,000 <sup>2</sup>					
Voltage range [V]	73-83	145-166	218-248	291-331	364-414	436-497
Nominal voltage [V]	77	154	230	307	384	461
Maximum charge / discharge current [A]	25/25					
Standby consumption [W]	<5					
<b>INTERFACES</b>						
Power Storage interface	CAN					
<b>GENERAL</b>						
Battery technology	LiFePO <sub>4</sub>					
Dimensions (H x W x D) [mm]	227×347 ×345	599×347 ×345	826×347 ×345	1053×347 ×345	1208×347 ×345	1507×347 ×345
Weight [kg]	25	59	84	109	134	159
Number of battery units	1	2	3	4	5	6
IP degree of protection	IP65					
Type of installation	Floor stand / Indoor / Outdoor					
Operating temperature range	-18~55°C (-0.4°F~131°F)					
Connector type	Quick Contact MC4-Evo 2					
<b>SAFETY / STANDARDS</b>						
Safety class	I					
Certificates	UN 38.3, UL1973, UL60730-1, UL9540A, IEC60529, IEC60068-2-52, IEC60068-2-5					
EMC	FCC Part 15B, ICES-003, IEC 61000-6-1 & 6-3					
Safety	IEC 62477, IEC62040, IEC62619, IEC63056					
<b>WARRANTY</b>						
Warranty	10 years <sup>3</sup>					

<sup>1</sup> Parameters above are for a single battery pack. A minimum of two packs is required for system operation.

<sup>2</sup> Cycle life test conditions: @25°C±2°C, @90% DOD, @70% SOH.

<sup>3</sup> Test condition of 5.2°C ~ 44.8°C (41.4°F ~ 112.6°F), 0.3C charge and discharge rate and SOH=70%.

- For more information about Power Battery 5.0/7.5/10.0/12.5/15.0, Please download the User Manual via the following website link:  
<https://www.rct-power.com.cn>
- For Mobile App, Please download via the following QR code.



iOS App Store



Google Play Store

# STORAGE SYSTEMS RETHOUGHT.

Germany's Excellent Technology.

